

Features

- Output voltage ranges: Fixed range of 1.8V, 2.5V, 2.7V, 3.0V, 3.3V, 4.5V, 5.0V type.
- Highly accuracy: $\pm 2\%$
- Low voltage drop: 240mV (typ.), $V_{OUT}=5.0V$ at 300mA
- Maximum Input Voltage: 8V
- Guaranteed output current: 300mA
- Low quiescent current: 4 μ A (typ.)
- Current limiting
- Over-temperature shutdown
- 3-pin SOT23, 5-pin SOT23 and 3-pin SOT89 Packages

Applications

- Portable electronics
- Wireless devices
- Cordless phones
- PC peripherals
- Battery powered devices
- Electronic scales

General Description

The AX72xx series of positive, linear regulators features low quiescent current (4 μ A typ.) with low dropout voltage, making them ideal for battery applications. The space-saving 3-pin SOT23 package is attractive for "Pocket" and "Hand Held" applications. The devices are capable of supplying 300mA of output current continuously.

They are available with several fixed output voltages ranging from 1.8V to 5.0V. Although designed primarily as fixed voltage regulators, these devices can be used with external components to obtain variable voltages and currents.

These rugged devices have Thermal Shutdown and Current Limiting to prevent device failure under the "Worst" of operating conditions.

Selection Table

Part No.	Output Voltage	Tolerance	Package	Marking
AX7218	1.8V	$\pm 2\%$	SOT23 SOT23-5 SOT89	72xx (for SOT23) 72xx (for SOT23-5) AX72xx (for SOT89)
AX7225	2.5V			
AX7227	2.7V			
AX7230	3.0V			
AX7233	3.3V			
AX7245	4.5V			
AX7250	5.0V			

Note: "xx" stands for output voltages.

Block Diagram

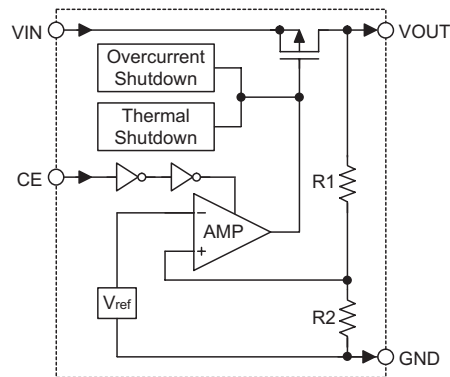

Pin Assignment

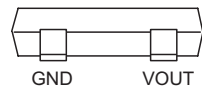
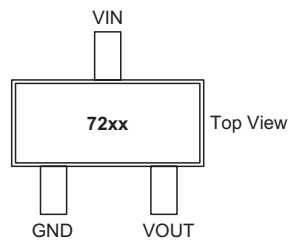
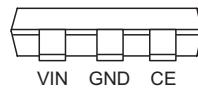
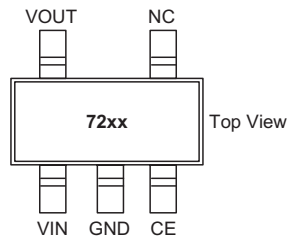
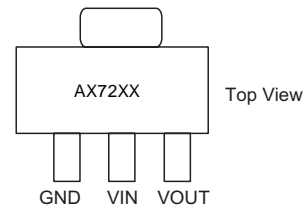
SOT23

SOT23-5

SOT89

Pin Description

Pin No.			Pin Name	Description
SOT23	SOT23-5	SOT89		
—	3	—	CE	Chip enable pin, high enable
2	5	3	VOUT	Output pin
3	1	2	VIN	Input pin
1	2	1	GND	Ground pin
—	4	—	NC	No connection

Absolute Maximum Ratings*

Maximum Supply Voltage	Up to 8.5V	Storage Temperature	-50°C to 125°C
Operating Temperature	-40°C to 85°C	Maximum Junction Temperature	150°C

Note: These are stress ratings only. Stresses exceeding the range specified under Absolute Maximum Ratings may cause substantial damage to the device. Functional operation of this device at other conditions beyond those listed in the specification is not implied and prolonged exposure to extreme conditions may affect device reliability.

* Absolute maximum ratings indicate limits beyond which damage to the device may occur. Operating Ratings indicate conditions for which the device is intended to be functional, but do not guarantee specific performance limits.

The guaranteed specifications apply only for the test conditions listed.

Thermal Information

Symbol	Parameter	Package	Max.	Unit
θ_{JA}	Thermal Resistance (Junction to Ambient) (Assume no ambient airflow, no heat sink)	SOT23	667	°C/W
		SOT23-5	500	°C/W
		SOT89	200	°C/W
P_D	Power Dissipation	SOT23	0.15	W
		SOT23-5	0.20	W
		SOT89	0.50	W

Note: P_D is measured at $T_a = 25^\circ\text{C}$

Electrical Characteristics

$T_j = 25^\circ\text{C}$, $V_{IN} = V_{OUT} + 1.0\text{V}$, $I_O = 1\text{mA}$, unless otherwise specified

Symbol	Parameter	Test Conditions	Min.	Typ.	Max.	Unit
V_{IN}	Input Voltage	—	—	—	8	V
ΔV_{OUT}	Output Voltage Tolerance	—	-2	—	2	%
I_{SS}	Quiescent Current	$I_O = 0\text{mA}$, $V_{CE} = V_{IN}$	—	4	7	μA
ΔV_{LOAD}	Load Regulation (Note1)	$1\text{mA} \leq I_{OUT} \leq 300\text{mA}$	—	0.004	0.008	%/mA
V_{DROP}	Dropout Voltage (Note2)	$\Delta V_{OUT} = 2\%$ $I_{OUT} = 300\text{mA}$ $V_O \leq 1.8\text{V}$	—	800	1200	mV
		$2.5\text{V} \leq V_O \leq 2.7\text{V}$	—	350	400	
		$3.0\text{V} \leq V_O \leq 5.0\text{V}$	—	240	300	
ΔV_{LINE}	Line Regulation	$V_{OUT} + 1.0\text{V} \leq V_{IN} \leq 8.0\text{V}$	—	0.2	0.3	%/V
I_{LIM}	Current Limit (Note3)	$\Delta V_{OUT} = 10\%$	300	—	—	mA
V_{IH}	CE Input High Threshold	$V_{OUT} + 1\text{V} \leq V_{IN} \leq 8\text{V}$	2	—	—	V
V_{IL}	CE Input Low Threshold	$V_{OUT} + 1\text{V} \leq V_{IN} \leq 8\text{V}$	—	—	0.8	V
I_{SD}	Shutdown Current	CE input voltage $\leq 0.8\text{V}$	—	0.5	1.0	μA
$\frac{\Delta V_{OUT}}{\Delta T_a}$	Temperature Coefficient	$-40^\circ\text{C} < T_a < 85^\circ\text{C}$	—	± 0.8	—	$\text{mV}/^\circ\text{C}$

Note: 1. Load regulation is measured at a constant junction temperature, using pulse testing with a low ON time and is guaranteed up to the maximum power dissipation. Power dissipation is determined by the input/output differential voltage and the output current. Guaranteed maximum power dissipation will not be available over the full input/output range. The maximum allowable power dissipation at any ambient temperature is $P_D = (T_{J(MAX)} - T_a) / \theta_{JA}$.

2. Dropout voltage is defined as the input voltage minus the output voltage that produces a 2% change in the output voltage from the value at $V_{IN} = V_{OUT} + 1\text{V}$ with a fixed load.

3. Current limit is measured by pulsing for a short time.

Application Circuit

The circuits provided in this section are for reference only.

For the purposes of clarity some of the detailed components parameters shall depend on the application.

Basic Circuits

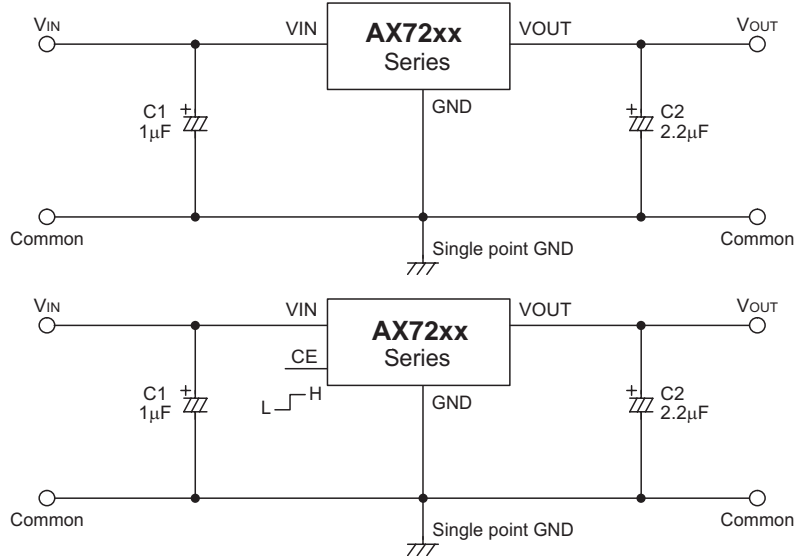

$$\frac{R2}{R1}$$

Typical Application Circuits

High Output Current Positive Voltage Regulator

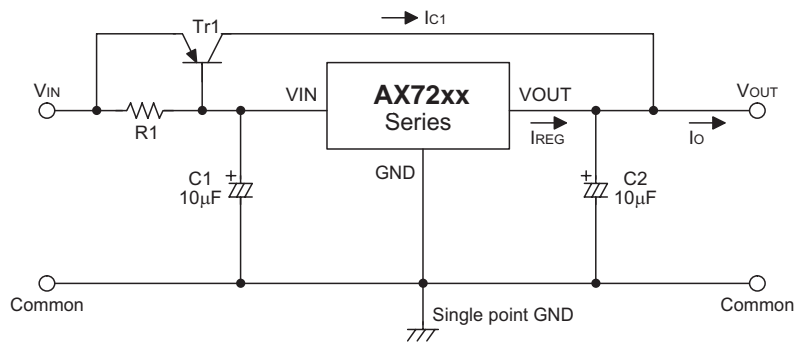

$$R1 = \frac{V_{BE1}}{I_{REG} - \frac{I_{C1}}{(1+\beta)}}$$

$$I_o = I_{C1} + I_{REG}$$

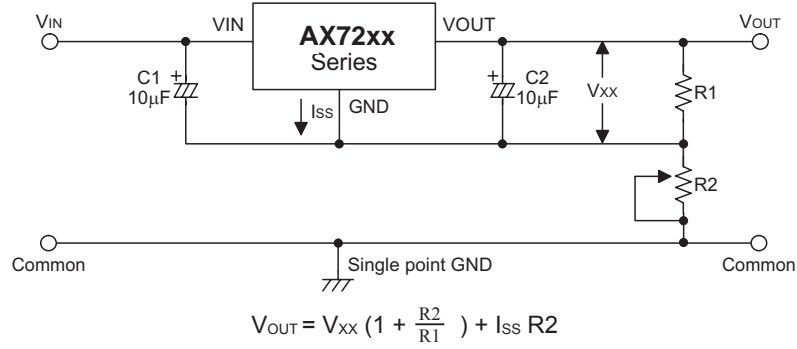
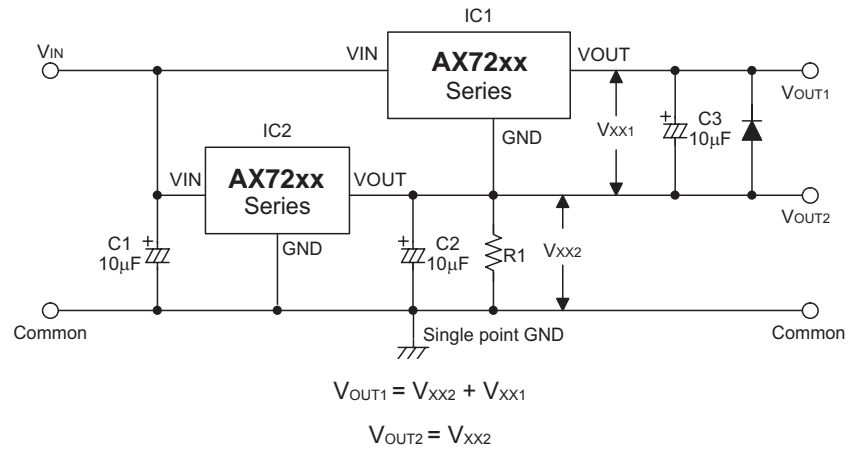
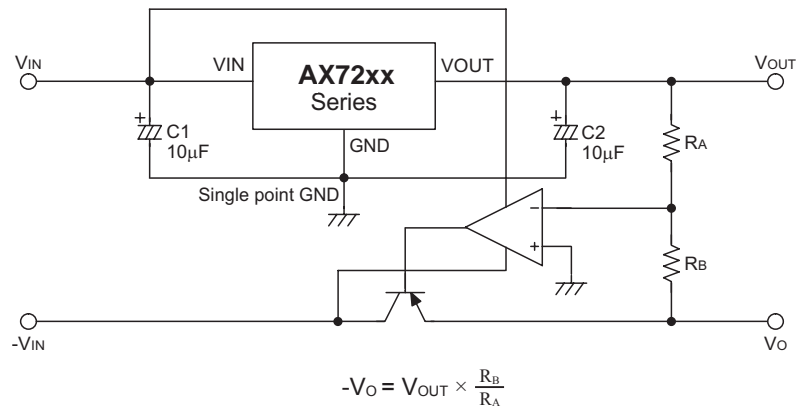
Increased Output Voltage Circuit

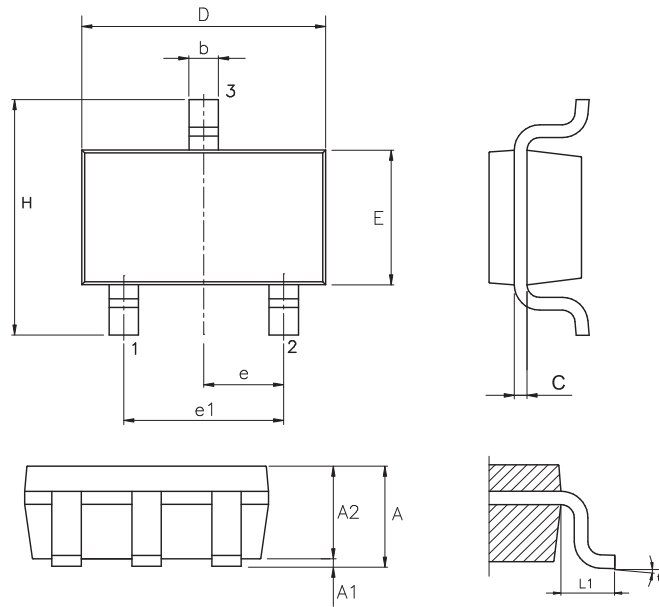
Dual Supply Circuit

Tracking Voltage Regulator

3-pin SOT23 Outline Dimensions

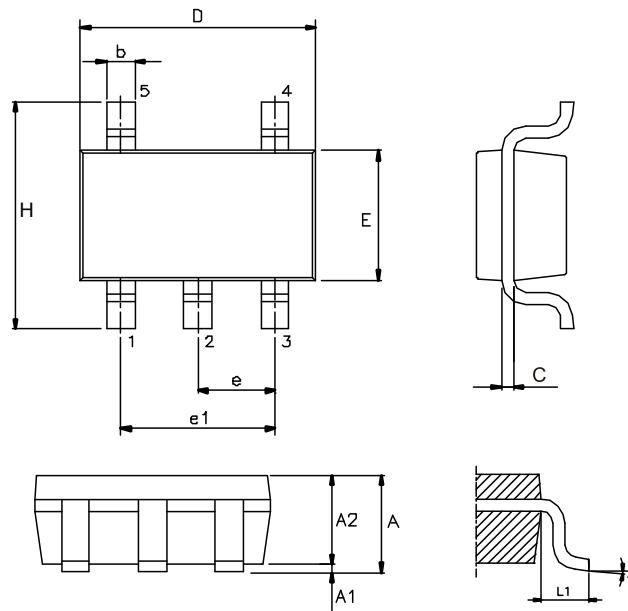
Symbol	Dimensions in inch		
	Min.	Nom.	Max.
A	—	—	0.057
A1	—	—	0.006
A2	0.035	0.045	0.051
b	0.012	—	0.020
C	0.003	—	0.009
D	—	0.114 BSC	—
E	—	0.063 BSC	—
e	—	0.037 BSC	—
e1	—	0.075 BSC	—
H	—	0.110 BSC	—
L1	—	0.024 BSC	—
θ	0°	—	8°

Symbol	Dimensions in mm		
	Min.	Nom.	Max.
A	—	—	1.45
A1	—	—	0.15
A2	0.90	1.15	1.30
b	0.30	—	0.50
C	0.08	—	0.22
D	—	2.90 BSC	—
E	—	1.60 BSC	—
e	—	0.95 BSC	—
e1	—	1.90 BSC	—
H	—	2.80 BSC	—
L1	—	0.60 BSC	—
θ	0°	—	8°

5-pin SOT23 Outline Dimensions

Symbol	Dimensions in inch		
	Min.	Nom.	Max.
A	—	—	0.057
A1	—	—	0.006
A2	0.035	0.045	0.051
b	0.012	—	0.020
C	0.003	—	0.009
D	—	0.114 BSC	—
E	—	0.063 BSC	—
e	—	0.037 BSC	—
e1	—	0.075 BSC	—
H	—	0.110 BSC	—
L1	—	0.024 BSC	—
θ	0°	—	8°

Symbol	Dimensions in mm		
	Min.	Nom.	Max.
A	—	—	1.45
A1	—	—	0.15
A2	0.90	1.15	1.30
b	0.30	—	0.50
C	0.08	—	0.22
D	—	2.90 BSC	—
E	—	1.60 BSC	—
e	—	0.95 BSC	—
e1	—	1.90 BSC	—
H	—	2.80 BSC	—
L1	—	0.60 BSC	—
θ	0°	—	8°

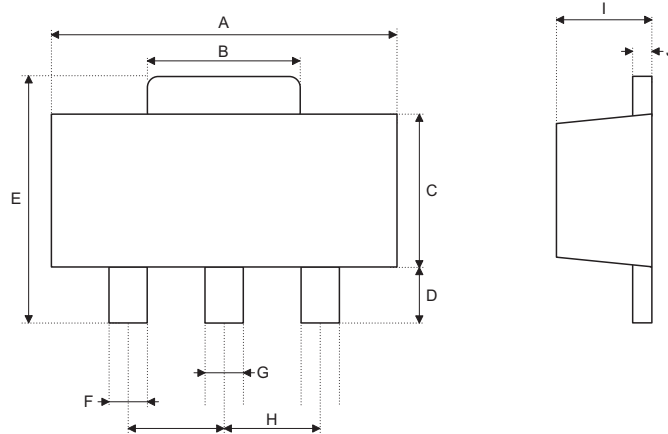
3-pin SOT89 Outline Dimensions

Symbol	Dimensions in inch		
	Min.	Nom.	Max.
A	0.173	—	0.185
B	0.053	—	0.072
C	0.090	—	0.106
D	0.031	—	0.047
E	0.155	—	0.173
F	0.014	—	0.019
G	0.017	—	0.022
H	—	0.059 BSC	—
I	0.055	—	0.063
J	0.014	—	0.017

Symbol	Dimensions in mm		
	Min.	Nom.	Max.
A	4.40	—	4.70
B	1.35	—	1.83
C	2.29	—	2.70
D	0.80	—	1.20
E	3.94	—	4.40
F	0.36	—	0.48
G	0.44	—	0.56
H	—	1.50 BSC	—
I	1.40	—	1.60
J	0.35	—	0.44